

ドリルソケット

HORIUCHI MFG. CO., LTD.



同じ寸法で2種類の焼入方法の中からお選び下さい。

総研磨総焼入

総研磨高周波部分焼入
(ϕ_7 及び ϕ_8 部分のみ)

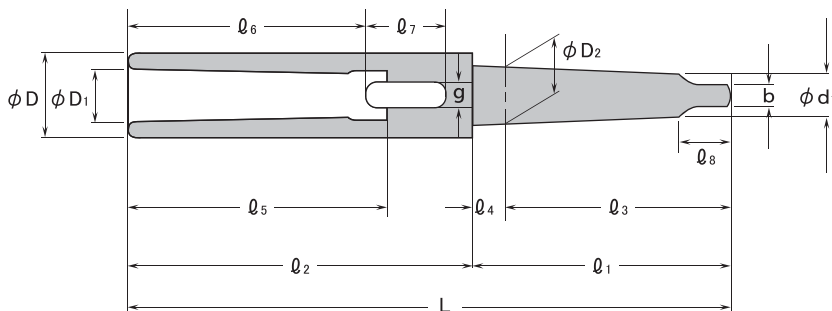
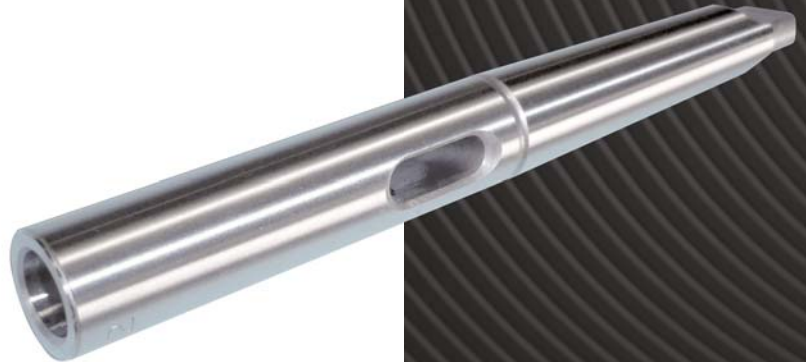

仕様寸法表 (単位:mm)

型式(内×外) MTNo.×MTNo.	D	D ₁	D ₂	d ₁	b	g	L	ϕ_1	ϕ_2	ϕ_3	ϕ_4	ϕ_5	ϕ_6	ϕ_7	ϕ_8
1×1	18	12.065	12.065	8.927	5.2	5.4	142.5	65.5	77	62.0	3.5	56	52	19	13.5
1×2	18	12.065	17.780	14.059	6.3	5.4	157.0	80.0	77	75.0	5.0	56	52	19	16.0
1×3	18	12.065	23.825	19.132	7.9	5.4	176.0	99.0	77	94.0	5.0	56	52	19	20.0
1×4	18	12.065	31.267	25.154	11.9	5.4	201.0	124.0	77	117.5	6.5	56	52	19	24.0
1×5	18	12.065	44.399	36.547	15.9	5.4	233.0	156.0	77	149.5	6.5	56	52	19	29.0
2×1	24	17.780	12.065	8.927	5.2	6.6	158.5	65.5	93	62.0	3.5	67	62	22	13.5
2×2	24	17.780	17.780	14.059	6.3	6.6	173.0	80.0	93	75.0	5.0	67	62	22	16.0
2×3	24	17.780	23.825	19.132	7.9	6.6	192.0	99.0	93	94.0	5.0	67	62	22	20.0
2×4	24	17.780	31.267	25.154	11.9	6.6	217.0	124.0	93	117.5	6.5	67	62	22	24.0
2×5	24	17.780	44.399	36.547	15.9	6.6	249.0	156.0	93	149.5	6.5	67	62	22	29.0
3×2	32	23.825	17.780	14.059	6.3	8.2	195.0	80.0	115	75.0	5.0	84	78	27	16.0
3×3	32	23.825	23.825	19.132	7.9	8.2	214.0	99.0	115	94.0	5.0	84	78	27	20.0
3×4	32	23.825	31.267	25.154	11.9	8.2	239.0	124.0	115	117.5	6.5	84	78	27	24.0
3×5	32	23.825	44.399	36.547	15.9	8.2	271.0	156.0	115	149.5	6.5	84	78	27	29.0
4×2	46	31.267	17.780	14.059	6.3	12.2	220.0	80.0	140	75.0	5.0	107	98	32	16.0
4×3	46	31.267	23.825	19.132	7.9	12.2	239.0	99.0	140	94.0	5.0	107	98	32	20.0
4×4	46	31.267	31.267	25.154	11.9	12.2	264.0	124.0	140	117.5	6.5	107	98	32	24.0
4×5	46	31.267	44.399	36.547	15.9	12.2	296.0	156.0	140	149.5	6.5	107	98	32	29.0
4×6	46	31.267	63.348	52.419	19.0	12.2	358.0	218.0	140	210.0	8.0	107	98	32	40.0
5×3	64	44.399	23.825	19.132	7.9	16.2	273.0	99.0	174	94.0	5.0	135	125	38	20.0
5×4	64	44.399	31.267	25.154	11.9	16.2	298.0	124.0	174	117.5	6.5	135	125	38	24.0
5×5	64	44.399	44.399	36.547	15.9	16.2	330.0	156.0	174	149.5	6.5	135	125	38	29.0
5×6	64	44.399	63.348	52.419	19.0	16.2	392.0	218.0	174	210.0	8.0	135	125	38	40.0